

CityScape

Aluminium Shutter System

TAKE CONTROL OF THE LIGHT, AIRFLOW
AND TEMPERATURE OF YOUR HOME.

1300 ALSPEC (257732)
alspec.com.au

alspec
ALUMINIUM SYSTEMS
SPECIALISTS

Alspec's CityScape Revolution

The CityScape™ aluminium shutter collection is a perfect solution to enhance your living areas by seamlessly blending your indoor and outdoor spaces. Combining core elements of design, strength and flexibility, CityScape™ aluminium shutters enable alfresco living all year round. By providing the right mix of light, airflow and temperature control, this opening solution allows you to maximise your lifestyle and enhance the appeal of your home.

Alspec's latest evolution of our CityScape™ aluminium shutter range has been built on the back of our extensive pedigree as Australia's leading designer of sophisticated aluminium systems. With a design that incorporates an outstanding modern shutter look, improved functionality, as well as enhanced strength and rigidity with the use of structural alloys, CityScape™ is the perfect solution for internal and external operable shutters.

Reduced Fabrication Time

The new CityScape™ suite has been designed to eliminate waste through improvements in fabrication and assembly time. These improvements mean a more economical product for the home owner. This has been achieved through:

- Simple square cuts on frames.
- Pre-punched powder coated stiles.
- Inclusion of calculation tables to improve quotation time.
- New spring loaded, UV stabilised glass filled nylon end caps with stainless steel pins.
- Modified screw flutes reduce "snap offs" and head stripping.
- Accommodates a range of Alspec hardware for use in multiple applications.

Environmentally Friendly

- 100% Recyclable Aluminium.
- CityScape Shutters reduce direct sunlight and heat transfer.
- Adjustable blades maximise natural ventilation.

Elegant Smart Design

- Fixed, Hinged, Bi-Fold or Sliding Options.
- Flexible fitting options to exceed market requirements.
- Available in both powder coated and timber grain finishes.
- Improved functional design reduces fabrication time and eliminates waste.
- Insect screen options available.

Built to Last

- Aluminium will not rust, rot, crack or perish under Australia's harsh conditions.
- New frame design improves strength and rigidity.
- Long Life Stainless Steel Hardware used throughout.

Key Features

- Centralised rail fin enables full blade rotation in either direction.
- New tilt bar design blocks light penetration.
- Inclusion of the variable rail enhances the panel size configuration options to fit all openings.
- Punched and powder coated stiles improve corrosion resistance and eliminate noisy shutters.
- Huge range of accessories including fly screen adaptors.
- Wide range of fitting options:
 - Fixed Panels
 - Hinged
 - Bi-Fold
 - Sliding (top hung and bottom rolling)

Technical Specifications

Fixed Panels	
Maximum Height	3000mm
Maximum Width	1000mm

Bi-Fold Panels	
Maximum Height	2400mm
Maximum Width	1000mm
Maximum Panel Weight	25kg

Sliding Panels	
Maximum Height	3000mm
Maximum Width	1000mm
Maximum Panel Weight	40kg

Refer to tech manual for maximum panel height and width. Sizes must be checked against wind loading tables for suitability.

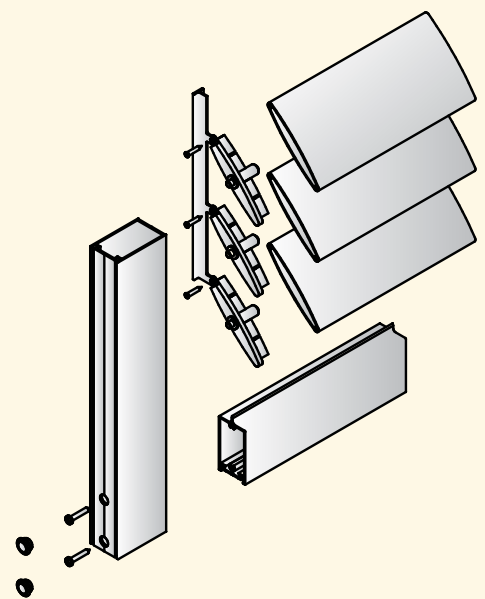

ALS-B37 NOV 2018